

6110  
SLANT BOARD

# IMPORTANT SAFETY INSTRUCTIONS

Thank you for purchasing the 6110 Slant Board.

- This machine is intended for household use only. It is not designed for commercial use.
- This manual is designed to help you to assemble, adjust, maintain and to use. Please read this manual carefully and follow it before you use your machine.
- Inspect your machine prior to exercise to ensure that all nuts and bolts are fully tightened.
- Most exercise equipment is not recommended for small children. Children should not use the machine unless they are under adult supervision.
- Exercise equipment has moving parts. In the interest of safety, keep others, especially children, at a safe distance while exercising.
- Warm up 5 to 10 minutes before each workout and cool down 5 to 10 minutes afterward. Never hold your breath while exercising.
- Rest adequately between workouts. Muscles tone and develop during these rest periods. Beginners should work out twice a week and increase gradually to 4 to 5 times per week.
- Remove all jewelry, including rings, chains and pins before commencing exercise. Always wear suitable clothing and footwear during exercise. Do NOT wear loose fitting clothing that could become entangled with the moving parts of your exercise machine.

## MEDICAL WARNING

- Before beginning any exercise program, consult your personal physician. Evaluate your present fitness level and determine the exercise program that is most appropriate for you particular age and condition.
- If you experience any pain or tightness in your chest, irregular heartbeats, shortness of breath, faintness or other unusual discomfort while exercising, stop and consult your physician before continuing

## TABLE OF CONTENTS:

Overview Of An Exercise Program	4
Weight Capacities	5
Parts List	6
Overview Drawing	7
Assembly steps	8-9
Customer service	10

# OVERVIEW OF AN EXERCISE PROGRAM

The guidelines below represent the basic components of safe and effective exercise program.

## Warm Up

3 to 5 minutes of low intensity aerobic or calisthenics type activity (sit up, push up, jumping jacks...etc)  
3 to 5 minutes of static stretching.

## Aerobic Training

Perform a minimum of 20 to 30 minutes of cardiovascular exercise, 3 to 5 days per week.

## Strength Training

Perform a total of 8 to 12 exercises, using all the major muscle groups, 2 to 3 times per week. A minimum of 1 set of 8 to 12 repetitions for each exercise should be performed to near muscle fatigue. Weight resistance should be increased by 5% to 10% when 12 repetitions can be completed in proper form at a given weight/resistance for desired number of sets. Rest a minimum of 48 hours, but not more than 96 hours, between strength training sessions that use the same muscle groups.

## MAXIMUM WEIGHT CAPACITY

The maximum recommended weight capacities for your 6110 Slant Board are as follows.

Maximum recommended exercise weights not to exceed:

*350* pounds

## MAINTENANCE

Your 6110 is a high quality machine and is built to last. Simple routine cleaning and preventive maintenance go a long way extending the life of your machine.

Inspect and Tighten all nuts and bolts each time you use the machine.

Replace the worn parts immediately.

# PARTS LIST

## Part Numbers & Description

1. Main support frame
2. Main upright
3. Upright extension
4. Foam roller cross tube
5. Adjustable foam roller tube
6. Plastic end cap (2"x2" tube)
7. Plastic end cap (2"dia tube)
8. Plastic end cap (1-1/2"dia tube)
9. Plastic end cap (1"dia tube)
10. Foam roller (2-5/8"OD x 5-3/4" Length)
11. Bolt M10x2-3/8" (60mm) (Upright)
12. Bolt M6x3/4" (20mm) (Foam pad)
13. Washer for M10 bolt
14. Washer for M6 bolt
15. Lock nut for M10 bolt
16. Knob (Adjustable foam roller tube)
17. Foam pad

# HARDWARE DRAWING

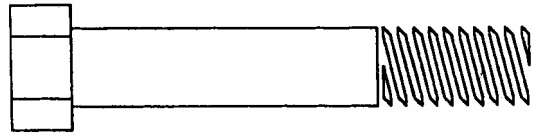

(11) Bolt M10x2-3/8"  
1 pc

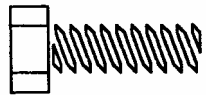

(12) Bolt  
M6x3/4"  
4 pcs

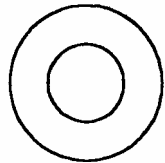

(13) Washer  
for M10 bolt  
2 pcs



(14) Washer  
for M6 bolt  
4 pcs



(15) Lock nut  
for M10 bolt  
1 pc

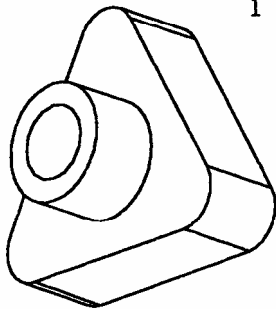

(16) Knob for M8 bolt  
1 pc

# OVERVIEW DRAWING

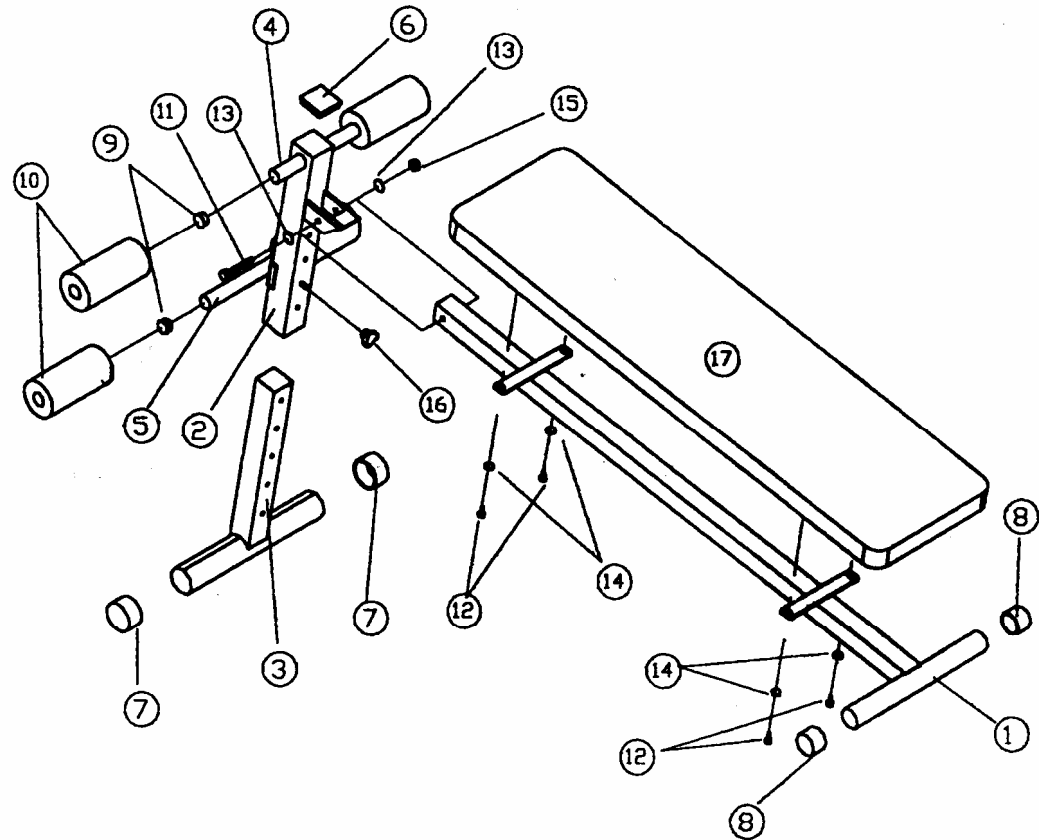

## ASSEMBLY STEPS

- STEP 1            Install the foam pad (17) onto the main support frame (1), using 4 bolts (M6x3/4") (12) and 4 washers (14). Tighten it securely.
- STEP 2            Connect the main support frame (1) to the main upright (2), using one bolt (M10x2-3/8") (11), 2 washers (13) and one lock nut (15). Tighten it with wrenches.
- STEP 3            Slide the upright extension (3) into the main upright (2), install the adjustable foam roller tube (5) and secure it with a Knob (16).
- STEP 4            Install the foam roller cross tube (4) to the main upright (2).
- STEP 5            Install the foam rollers (10) onto the foam roller tube (4 & 5).
- STEP 6            Install the foam pad (17) onto the main support frame (1) using 4 bolts (12) and 4 washers (14).

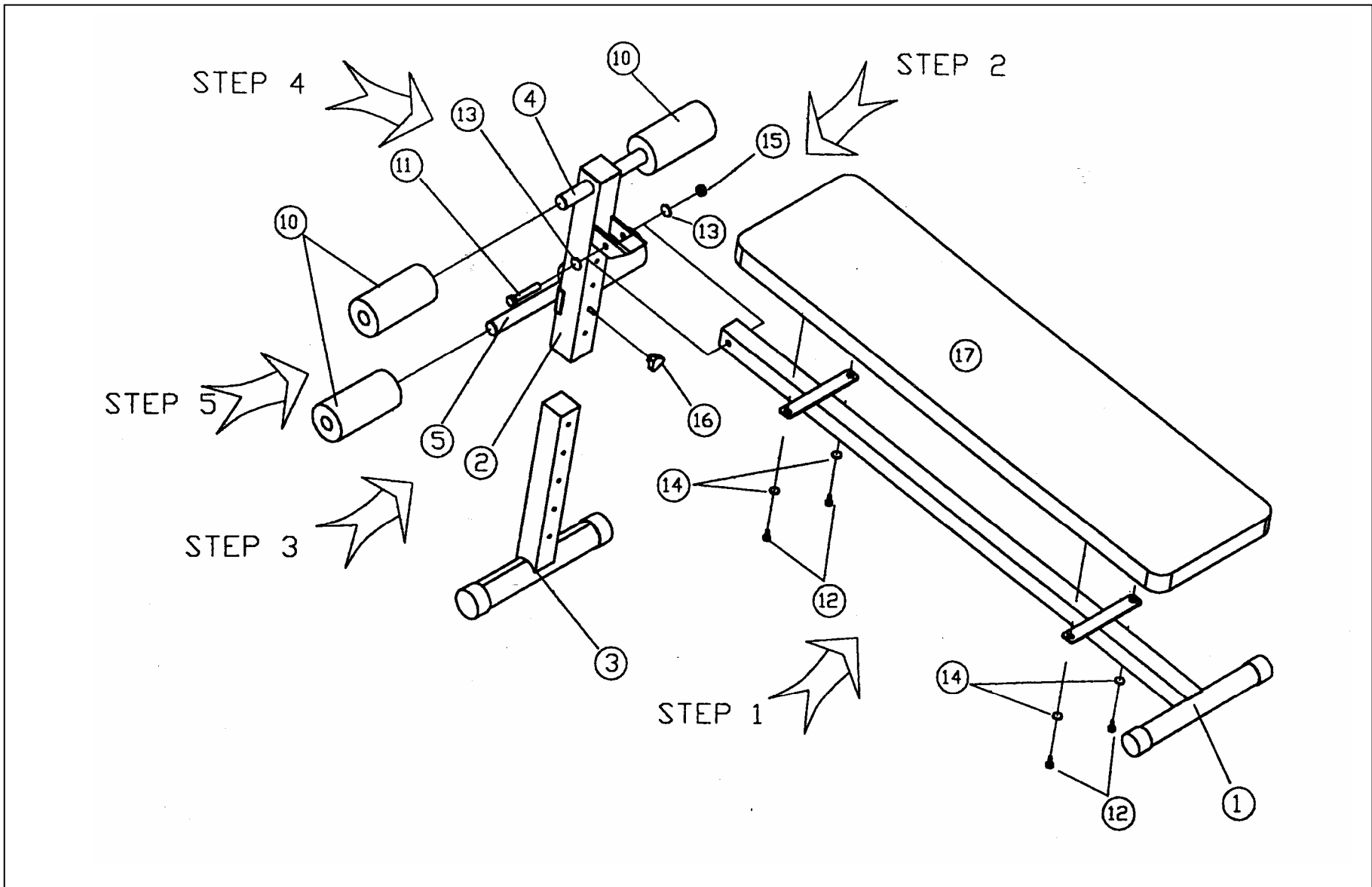

## CUSTOMER SERVICE

We have installed a convenient toll-free telephone hotline to serve our customers. A customer support specialist is available to answer any questions you may have.

**CUSTOMER SERVICE: Toll free: 866-856-3488 or 713-895-9270  
Monday-Friday 8:00am to 5:00pm CT**

Our Hotline number is: 866.856.3488 or Fax 781.895.9270 from all other areas. The service hours are 9:00 am to 5:00 pm Eastern Standard Time.

If the technician cannot resolve your problem over the phone, he/she will request that you return the problem part(s) to us (at TKO) for evaluation and repair or replacement. He/she will assign you a RAN (return goods authorization number). The RAN should be on the outside of the package that contains the item(s) to be returned. Forward the package to TKO Sports Group USA, Ltd. prepaid.

Merchandise returned without a RAN the outside of the package or shipments sent C.O.D. will not be accepted by the TKO receiving department (distribution center).

Goods damaged in shipment should not be returned for credit before notifying the freight carrier. Shipping damages are the responsibility of the freight carrier (UPS, Federal Express, Trucking companies, etc.).

Upon receiving the shipment, check the boxes carefully. Any damage seen with a visual check must be noted on the freight bill and signed by the carrier's agent. The freight carrier will provide you with the required forms for claims.

Failure to do so will result in the freight carrier's refusal to honor your damage claims.

Concealed damage is also the freight carrier's responsibility.



**TKO SPORTS GROUP USA, LTD.**

**7354 Denny Road #100  
Houston, TX 77040  
1-713-895-9270  
1-713-895-9379 Fx  
[www.tko.com](http://www.tko.com)**